

trouble shooting tips

No. 5 The Noisy Pump That Does not Pump

VAPOR PRESSURE AND ITS EFFECT ON PUMPING WITH A SUCTION PUMP

There seems to be some confusion and possibly a lack of knowledge over what many call "VAPOR Lock" in pumping systems. We are going to attempt, we hope, to clarify and not confuse the situation, and maybe pass on some information you did not have before.

"VAPOR Lock" is really a misnomer as nothing is "locked". It may seem that the pump has quit pumping but it has not. What has happened is that the Gasoline has turned from a liquid to a gas (or VAPOR). Because the Pump unit can no longer get liquid it "Cavitates", becoming very noisy, with vibration and slows its delivery dramatically.

However as most Service Station Pumps are positive displacement pumps (this means they must move something or something breaks) they are in fact pumping and what they are pumping is the gas or vapor. This gas or vapor is being discharged through the air eliminator if it is working properly, and is visible under right light conditions. It would be highly visible if you ignited it! Therefore it is not a condition where you want to leave the pump running.

Why did the liquid Gasoline turn to a gas? Well each liquid has a given "VAPOR Pressure" at given temperatures. This VAPOR Pressure is the lowest pressure which must be maintained on the liquid for the current temperature to keep it in liquid state.

What makes the situation confusing is that this pressure increases with temperature, and varies from liquid to liquid. Gasolines have a variety of VAPOR Pressures dependent upon the additives in them. Thus unleaded are different than leaded, premiums different than regular and winter grades different than summer grades.

A plus factor however is that at most ambient temperature ranges the VAPOR Pressure of Gasolines is less than normal atmospheric pressure, thus it will stay in liquid state without additional pressure being applied to it. This is not the case with liquids such as Propane which must be kept in a pressurized container to keep them liquid as atmospheric pressure alone will not do it.

Back to our Service Station Pump unit that is noisy and slow; how can we determine if we have gone below VAPOR Pressure?

The pump will cavitate if It can not get liquid.

A pump that is cavitating is:

Noisy

Full of vibration

experiencing a fluctuating or high Vacuum reading on Suction side.

experiencing a Low Pressure reading on Discharge side.

has extremely low flow If any.

To determine if we in fact are trying to pump below the VAPOR Pressure of the liquid we need the

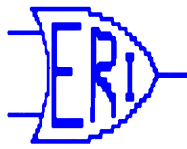

trouble shooting tips

following information:

A. The VAPOR Pressure of the Fuel and its current temperature.

The temperature should be measured at the discharge of the pump as the temperature in the pump and the lines will probably be higher than in the tank, particularly if there is not much cover, and asphalt instead of concrete over the lines. However it would be of interest to know the temperature in the tank as well.

The fuel supplier can give us the VAPOR Point of the fuel. They usually express it in terms of Reid VAPOR Pressure which is normally a 1 or 2 digit number. If they can give you a true VAPOR Pressure Curve for Various temperatures it would be better. However our Figure 1 will give you a rough conversion for some of the Reid VAPOR numbers to PSI absolute for some temperatures.

APPROXIMATE VAPOR PRESSURE - PSI Absolute
FUEL CHARACTERISTICS

	MOTOR		GASOLINE			
	WINTER	GASOLINE	SUMMER	GASOLINE	AVIATION	JET FUEL
TEMPERATURE	REID VAPOR PRESSURE 14 REID	12 REID	10 REID	8 REID		& KEROSENE
40°F	4.8	4.0	3.4	2.8	2.2	.9
50°F	5.9	4.9	4.1	3.4	2.8	1.0
60°F	7.4	6.0	5.0	4.1	3.5	1.0
70°F	8.9	7.4	6.0	5.0	4.2	1.2
80°F	10.7	9.0	7.1	5.9	5.1	1.4
90°F	12.8	10.6	8.6	7.0	6.2	1.7
100°F	14.0	12.0	10.0	8.0	7.4	2.0

Figure 1

It should be noted that the VAPOR pressures are getting higher in the newer fuels and higher in winter fuels than summer fuels. **Therefore it is a good to idea to check when the fuel was delivered (in some cases the delivery slip will give the Reid VAPOR Pressure of the fuel).** For our example let us say we are given Reid #12 and we measure its temperature as 78 deg. F.

B. The Suction needed to pull the fuel from the Tank to the Pump.

This can measured directly with Vacuum Gauge but will only be accurate if the problem is a blocked line or vent where you will get a steady high reading.

It can however be calculated (comparing this to the actual reading will determine if the line is blocked.) To do this we need the following information:

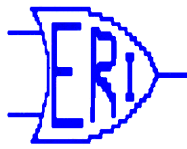

trouble shooting tips

- a. Height from center line of the pump to the level of the liquid in the tank.
- b. The length and size of the suction line including the equivalent length of pipe caused by fittings. (see figure 2 at end of document)
- c. The normal flow rate of the pump.

For our example lets assume (see drawing A at end of document)

- a. Height from C/L to liquid level is measured at 11 feet. From Curve (figure 3 at end of document) we see this is equal to 6.6 in. Hg.(Mercury).
- b. We determine that there is 60 feet of 2 in. pipe with 6 - 2 in 90 Deg. SR elbows. From Figure 2 we can determine that each elbow is equal to 5 feet of pipe. This gives us:

$$\begin{aligned} \text{Total pipe} &= 60 \text{ feet} \\ \text{Equiv. pipe from} \\ \text{fittings} &= 6 \times 5 = \underline{30 \text{ feet}} \\ \text{Total} &= 90 \text{ feet} \end{aligned}$$

- c. The normal flow rate of the pump from the name plate we find is 10 USGPM

To calculate our suction Lift:

- 1. Static Lift (C/L pump to liq. level) = 6.6 in.Hg.
- 2.Total equivalent length pipe = 90 feet
From figure 4 at 10 USGPM we need
0.2 in.Hg per 100 feet of pipe to overcome
friction loss in the pipe> Therefore to
calculate 90 feet/100 feet x 0.2 In. Hg. = 0.18 in.Hg.
Total suction lift 6.78 in.Hg.

Using the formula 1 in.Hg. = 0.489 PSI we get:

$$6.78 \text{ in.Hg.} \times 0.489 = 3.32 \text{ PSI}$$

C. The Current Atmospheric Pressure.

A quick phone call to you local weather office will give you this.

A call to our local hot line today gave me a current atmospheric pressure of 100.9 KPa (Kilopascals). The conversion to PSI is: 1 KPa = 0.145 PSI

Therefore our current atmospheric pressure is 100.9 KPa x 0.145 = 14.63 PSI,

To calculate If we have lowered the Pressure on the Gasoline below its VAPOR Pressure we use the following formula:

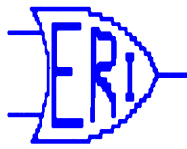

trouble shooting tips

ATMOSPHERIC PRESSURE - SUCTION LIFT = PRESSURE ON FUEL

Therefore from our example: 14.63 PSI - 3.32 PSI = 11.31 PSI

Now from our Figure 1 we determine that the VAPOR Pressure of our Reid #12 fuel at 78 deg. F is approx. 8.7 PSI and thus we are 11.31 PSI - 8.7 PSI = 2.61 PSI over the VAPOR Pressure point of the fuel and it should not be turning to a gas.

If However at B. where we calculated our Suction Lift as 6.78 in.Hg. Vacuum, with a Vacuum gauge we actually measured vacuum as high as 12 in.Hg. We would then come to the following result:

$$12 \text{ in.Hg.} \times 0.489 = 5.87 \text{ PSI (Actual Suction Lift)}$$

$$14.63 \text{ PSI} - 5.87 \text{ PSI} = 8.76 \text{ PSI (Pressure on liquid)}$$

$$8.7 \text{ PSI} - 8.76 \text{ PSI} = -0.06 \text{ PSI (Pressure below VAPOR Pressure)}$$

At this point we should look for a blockage in our Suction or Vent lines, or a high spot in the suction line.

But remember to first determine if there is an appreciable difference between the calculated Vacuum and the Actual Vacuum.

If you do this procedure you will save a lot of time looking for blocked lines that are not there when the problem could simply be a fuel with too high a VAPOR Point being too hot on a day with low atmospheric pressure.

An important note is that the most significant thing affecting the Suction Lift or Vacuum is the Static or Vertical lift and not the length of pipe. This means if you are having the problem on a tank that is low in fuel, simply filling it may eliminate the problem.

A couple of helpful manuals to get your hands on are Blackmer Pump's Bulletin 33 "Hydraulic Data for Pump Applications" and Marlow Pump's ITT "Engineering Manual".

Good luck on figuring these situations out!

SELF CONTAINED (SUCTION) PUMPS
Typical Installation Diagram

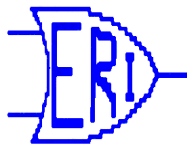

trouble shooting tips

Drawing A

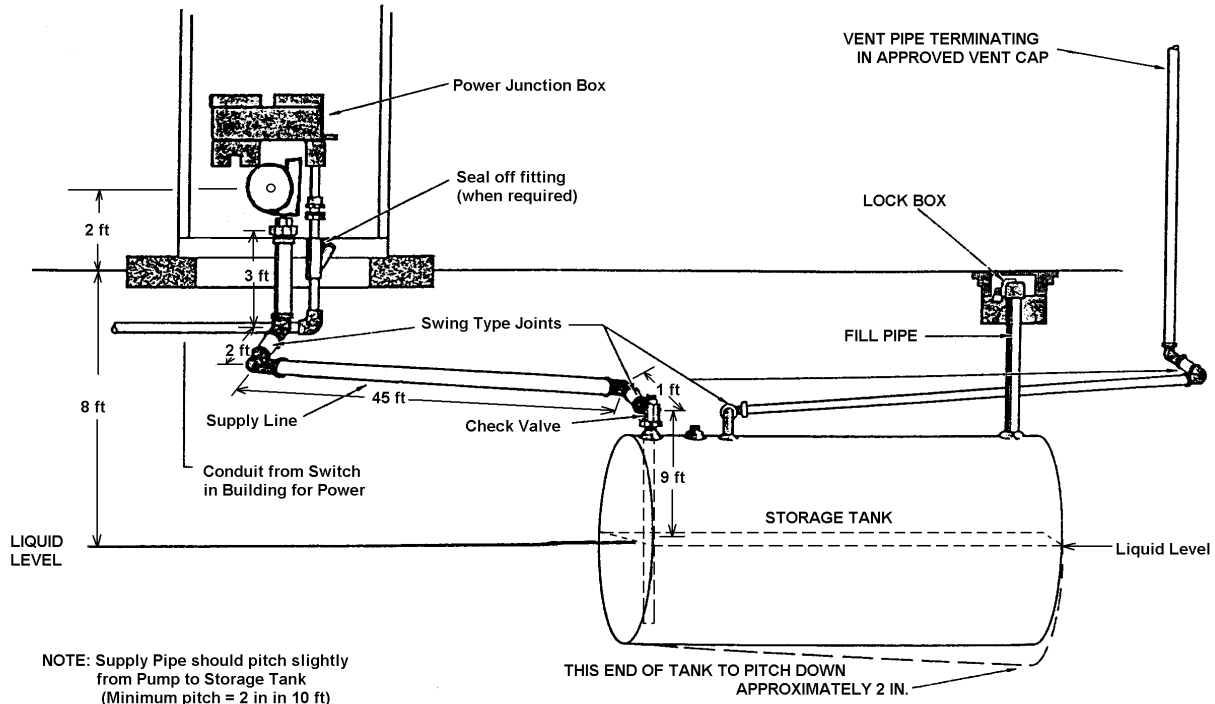

FRICITION LOSS IN VALVES AND FITTING

Shown in approximate equivalent length of straight pipe in feet

Type of Fitting	1 1/2in	2in	3in
Gate Valve - Fully Open	0.95	1.2	1.7
Globe Valve - Open	42	51	80
Angle Valve - Open	20	30	40
Standard Tee - through side outlet	9	12	16
Standard Tee - straight through	2.8	3.5	5
Standard Elbow	4.5	5.0	8
Medium Sweep Elbow	3.5	4.5	7
Long Sweep Elbow	2.8	3.5	5

Figure 2



trouble shooting tips

STATIC LIFT CONVERSION CHART

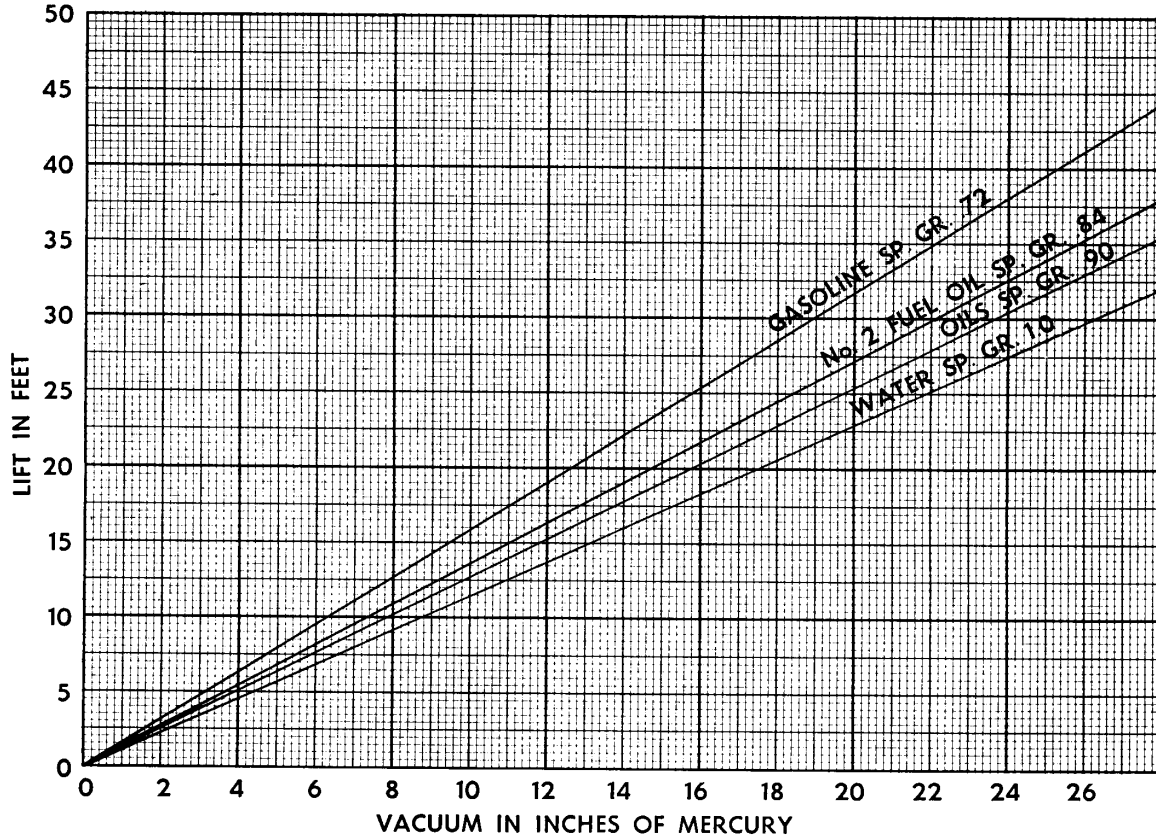

Figure 3

DIRECT READING FRICTION TABLE FOR 2 IN PIPE



trouble shooting tips

USGM	Gasoline Specific Gravity 0.72 Reading in inches of mercury (in.Hg.)
10	0.2
15	0.2
20	0.4
25	0.8
30	1.0
35	1.4
40	1.8
45	2.4
50	2.9
60	4.1
70	5.5
80	6.9
90	9.0
100	11.0
120	15.1

Figure 4